

VXC "VORTEX"

Submersible pumps

▣▣▣▣ for sewage water



PERFORMANCE RANGE

- Flow rate up to **1200 l/min** (72 m³/h)
- Head up to **16 m**

APPLICATION LIMITS

- **10 m** maximum immersion depth (with a sufficiently long power cable)
- Maximum liquid temperature **+40 °C**
- Solids passage:
 - up to **Ø 50 mm** for VXC 15-20-30/50
 - up to **Ø 70 mm** for VXC 15-20-30/70
- Minimum immersion depth for continuous service:
 - **390 mm** for VXC 15-20-30/50
 - **430 mm** for VXC 15-20-30/70

CONSTRUCTION AND SAFETY STANDARDS

- Complete with **10 m** long power cable
- Float switch for single-phase versions

EN 60034-1
IEC 60034-1
CEI 2-3



CERTIFICATIONS

COMPANY WITH MANAGEMENT SYSTEM
CERTIFIED BY DNV
ISO 9001: QUALITY
ISO 14001: ENVIRONMENT AND SAFETY



AN30



IPOMTECT-168

INSTALLATION AND USE

VXC series pumps, made from heavy gauge cast iron offering exceptional sturdiness, abrasion resistance and durability, come equipped with a VORTEX impeller and are therefore suitable for draining **waste water, sewage, water mixed with mud and sludge**. They are ideal for use in sewage installations, tunnels, excavations, canals and underground car parks, etc.

PATENTS - TRADE MARKS - MODELS

- Registered Community Design n° 342159-0017

OPTIONALS AVAILABLE ON REQUEST

- QES control box for three-phase pumps
- Single-phase pumps without float switch
- Other voltages or 60 Hz frequency

GUARANTEE

2 years subject to terms and conditions

▣▣▣▣ **For the following versions the built-in thermal overload protector must be connected to the control box in order for the guarantee to be considered valid:**

single-phase

- VXCm 30/50 - HP 3
- VXCm 30/70 - HP 3

three-phase

- VXC 15-20-30/50 - HP 1.5-2-3
- VXC 15-20-30/70 - HP 1.5-2-3

CHARACTERISTIC CURVES AND PERFORMANCE DATA

50 Hz n= 2900 1/min

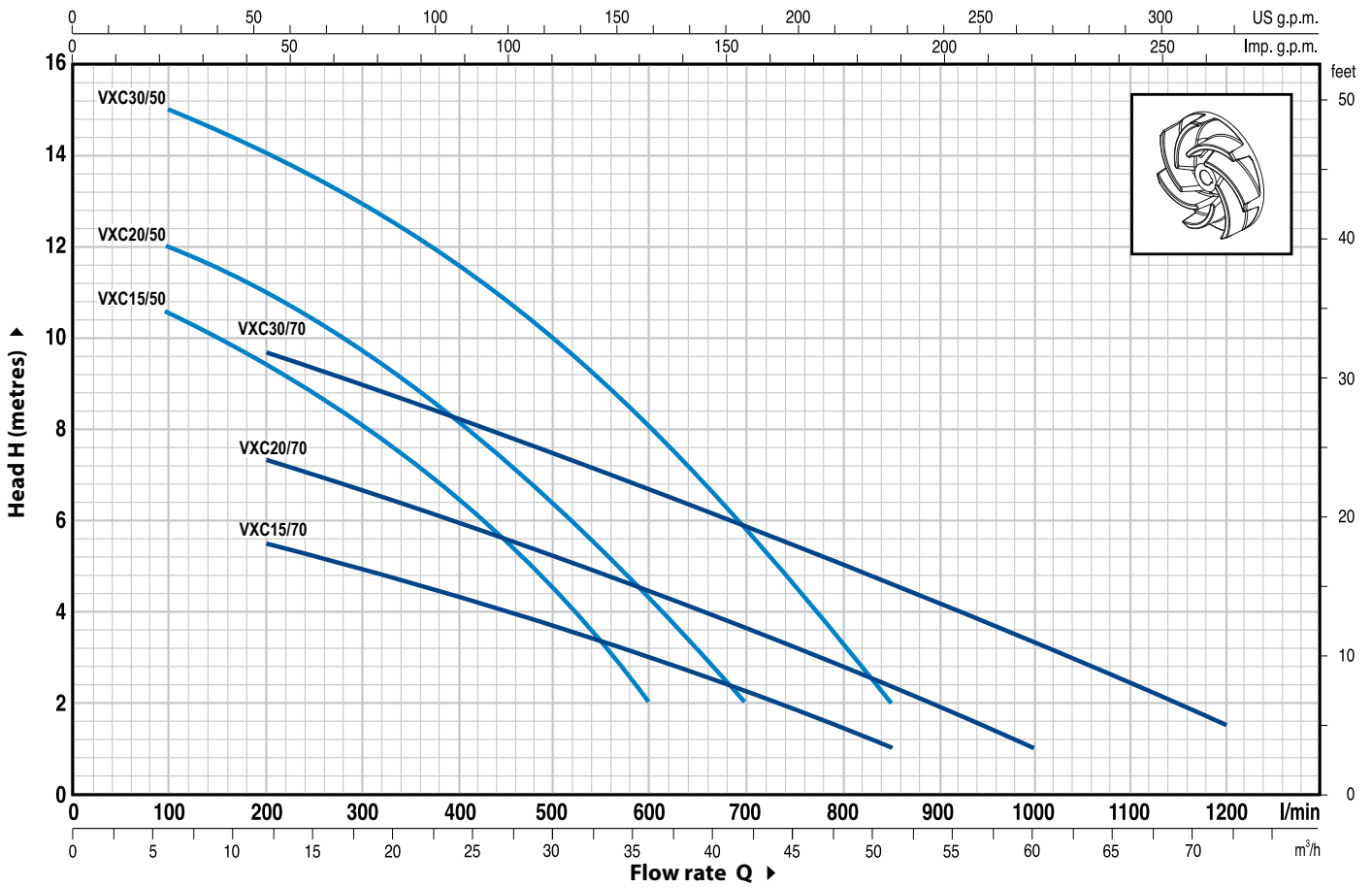

MODEL		POWER		Q	Flow rate																
Single-phase	Three-phase	kW	HP		m³/h	0	6	12	18	21	24	30	36	42	48	51	54	60	66	72	
				l/min	0	100	200	300	350	400	500	600	700	800	850	900	1000	1100	1200		
VXCm 15/50	VXC 15/50	1.1	1.5	H metres	11.5	10.5	9.5	8.2	7.2	6.5	4.5	2									
VXCm 20/50	VXC 20/50	1.5	2		13	12	11	9.5	9	8	6.5	4.5	2								
VXCm 30/50	VXC 30/50	2.2	3		16	15	14	13	12.3	11.5	10	8	5.9	3.3	2						
VXCm 15/70	VXC 15/70	1.1	1.5		6.5	-	5.5	5	4.7	4.4	3.7	3	2.2	1.5	1						
VXCm 20/70	VXC 20/70	1.5	2		8.5	-	7.4	6.7	6.3	6	5.2	4.5	3.6	2.8	2.4	2	1				
VXCm 30/70	VXC 30/70	2.2	3		11	-	9.7	9	8.6	8.2	7.5	6.7	5.8	5	4.6	4.2	3.3	2.5	1.5		

Q = Flow rate H = Total manometric head

Tolerance of characteristic curves in compliance with EN ISO 9906 Grade 3.

POS.	COMPONENT	CONSTRUCTION CHARACTERISTICS				
1	PUMP BODY	Cast iron, with threaded port in compliance with ISO 228/1				
2	BASE	Stainless steel AISI 304				
3	IMPELLER	Cast iron VORTEX type				
4	MOTOR CASING	Cast iron				
5	MOTOR CASING PLATE	Cast iron				
6	MOTOR SHAFT	Stainless steel AISI 431				
7	TWO MECHANICAL SEALS SEPARATED BY AN OIL CHAMBER					
	<i>Seal</i>	<i>Shaft</i>	<i>Position</i>	<i>Stationary ring</i>	<i>Rotational ring</i>	<i>Materials</i>
	<i>Model</i>	<i>Diameter</i>				<i>Elastomer</i>
	STA-20	Ø 20 mm	Motor side	Ceramic	Graphite	NBR
	STA-19	Ø 19 mm	Pump side	Silicon carbide	Silicon carbide	NBR
8	BEARINGS	6304 ZZ - C3 / 6304 ZZ - C3				
9	CAPACITOR					
	<i>Pump</i>	<i>Capacitance</i>				
	<i>Single-phase</i>	<i>(230 V or 240 V)</i>				
	VXCm 15/50	31.5 µF 450 VL				
	VXCm 15/70	31.5 µF 450 VL				
	VXCm 20/50	50 µF 450 VL				
	VXCm 20/70	50 µF 450 VL				
	VXCm 30/50	60 µF 450 VL				
	VXCm 30/70	60 µF 450 VL				
10	ELECTRIC MOTOR					
	VXCm 15-20: single-phase 230 V - 50 Hz with thermal overload protector built-in to the winding					
	⇒ VXCm 30: single-phase 230 V - 50 Hz with thermal overload protector built-in to the winding to be connected to the control box.					
	⇒ VXC: three-phase 400 V - 50 Hz. with thermal overload protector built-in to the winding to be connected to the control box.					
	– Insulation: F class.					
	– Protection: IP X8.					
11	POWER CABLE		10 metre long "H07 RN-F" cable			
12	CONTROL BOX for VXCm 15-20		(only for single-phase versions)			
	Complete with capacitor and manual reset motor protector					
13	CONTROL BOX for VXCm 30		(only for single-phase versions)			
	QES 300 MONO series					
14	FLOAT SWITCH		(only for single-phase versions)			

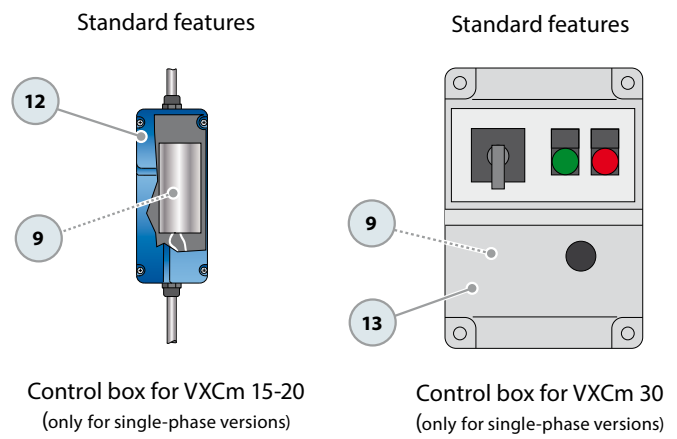
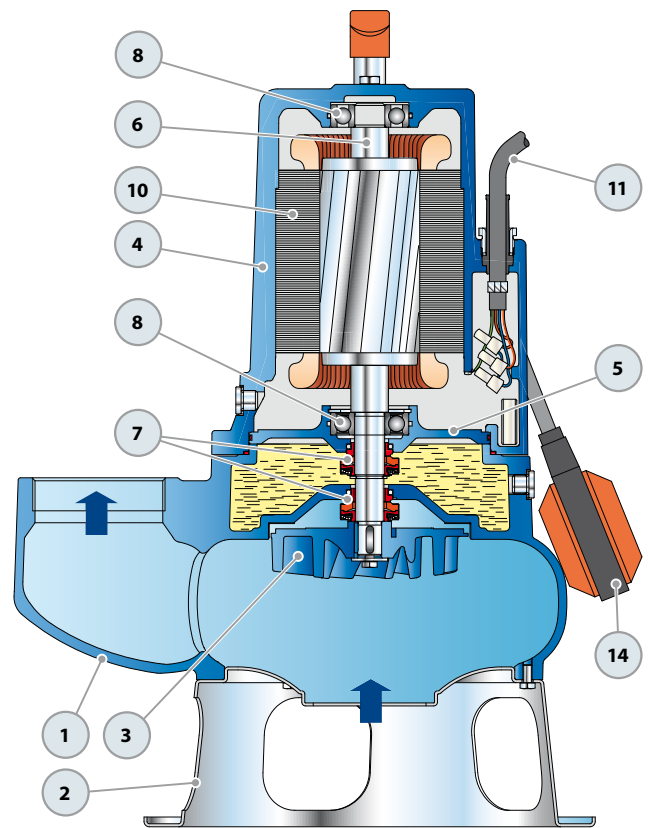

DIMENSIONS AND WEIGHT

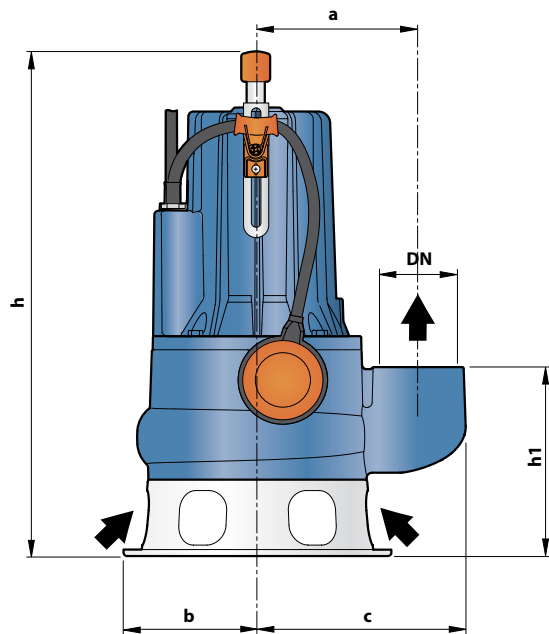

Typical installation

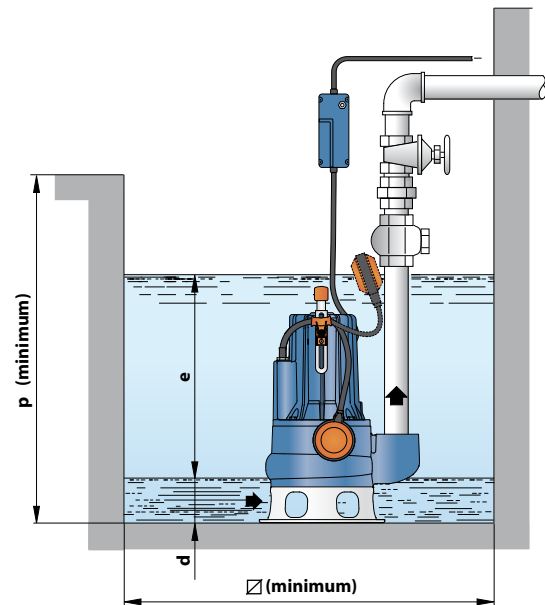

MODEL		PORT DN	solids passage	DIMENSIONS mm									kg	
Single-phase	Three-phase			a	b	c	h	h1	d	e	p	Ø	1~	3~
VXCm 15/50	VXC 15/50	2½"	Ø 50 mm	162	135	210	509	191	75	variable	800	800	36.2	34.9
VXCm 20/50	VXC 20/50						522/509						37.3	36.0
VXCm 30/50	VXC 30/50						562/548						41.2	38.0
VXCm 15/70	VXC 15/70	3"	Ø 70 mm	180	150	237	548	233	85				36.4	35.1
VXCm 20/70	VXC 20/70						562/548						37.5	36.2
VXCm 30/70	VXC 30/70						562/548						41.5	38.3

ABSORPTION

MODEL	VOLTAGE (single-phase)	
	230 V	240 V
VXCm 15/50	8.8 A	8.8 A
VXCm 20/50	10.2 A	10.2 A
VXCm 30/50	15.6 A	15.6 A
VXCm 15/70	8.7 A	8.7 A
VXCm 20/70	10.0 A	10.0 A
VXCm 30/70	15.0 A	15.0 A

MODEL	VOLTAGE (three-phase)					
	230 V	400 V	690 V	240 V	415 V	720 V
VXC 15/50	5.9 A	3.4 A	2.0 A	5.9 A	3.4 A	2.0 A
VXC 20/50	7.3 A	4.2 A	2.4 A	7.3 A	4.2 A	2.4 A
VXC 30/50	9.9 A	5.7 A	3.3 A	9.9 A	5.7 A	3.3 A
VXC 15/70	5.7 A	3.3 A	1.9 A	5.7 A	3.3 A	1.9 A
VXC 20/70	7.3 A	4.2 A	2.4 A	7.3 A	4.2 A	2.4 A
VXC 30/70	9.5 A	5.5 A	3.2 A	9.5 A	5.5 A	3.2 A

PALLETIZATION

MODEL		GROUPAGE / CONTAINER			
Single-phase	Three-phase	n° pumps	H (mm)	kg	
				1~	3~
VXCm 15/50	VXC 15/50	24	1751	887	855
VXCm 20/50	VXC 20/50	24	1751	913	882
VXCm 30/50	VXC 30/50	24	1751	1007	930
VXCm 15/70	VXC 15/70	12	1304	454	438
VXCm 20/70	VXC 20/70	12	1304	467	451
VXCm 30/70	VXC 30/70	12	1304	515	477

